

PRESSURE PLATE
(MOVABLE)

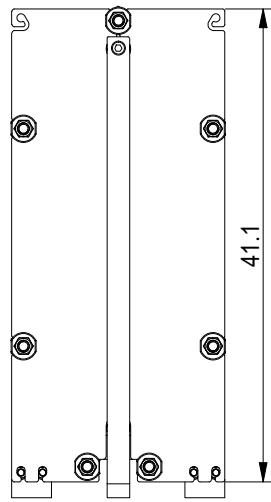

Space between pressure plate and supporting column should be kept free from fixed installations!

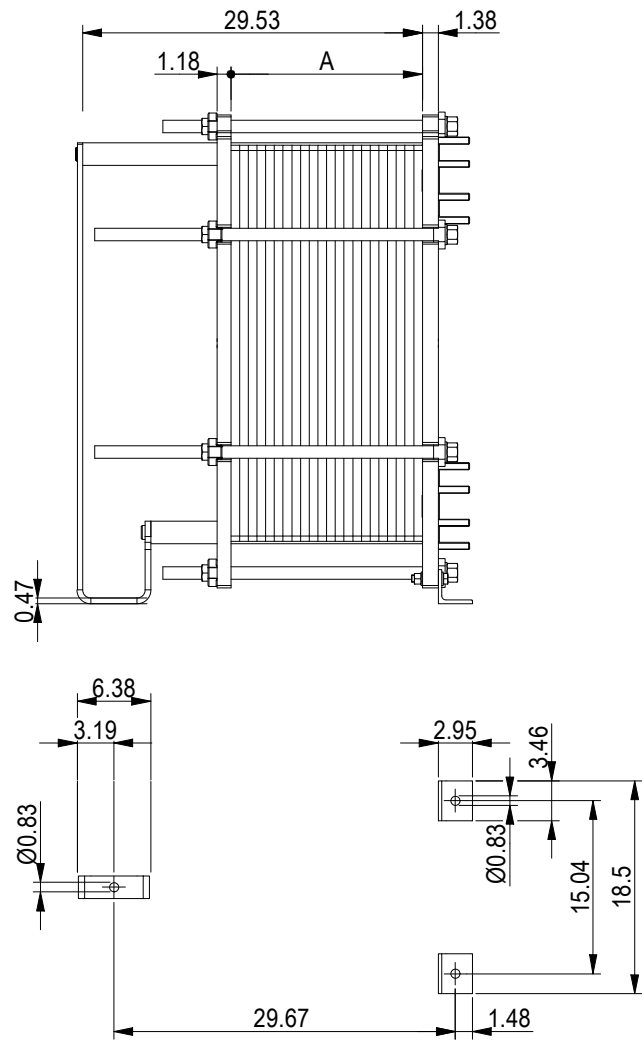

FRAME PLATE

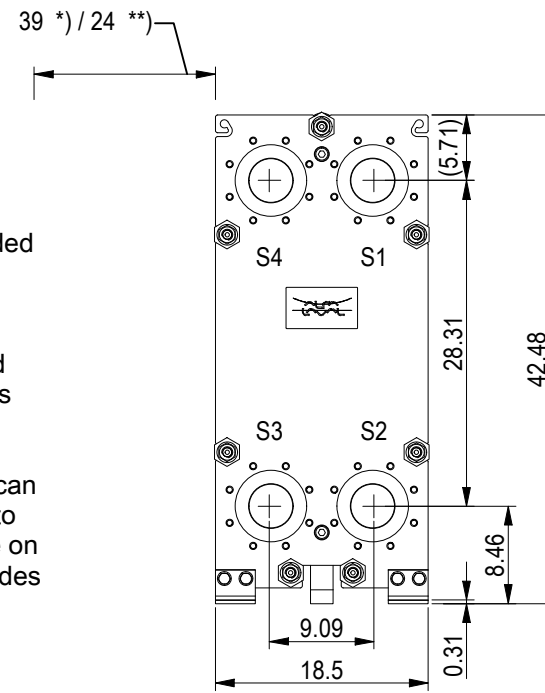

*) Recommended free space for opening and closing to be applied on both sides

**) Free space can be reduced to this distance on one of the sides

All dimensions in inches

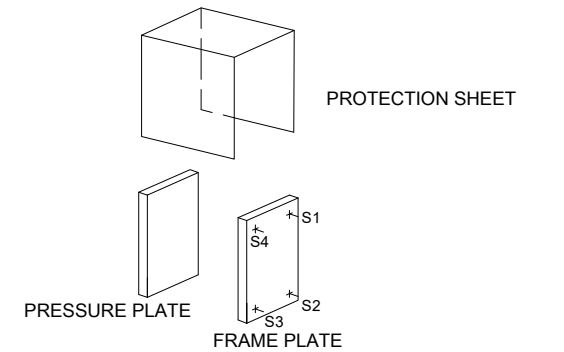
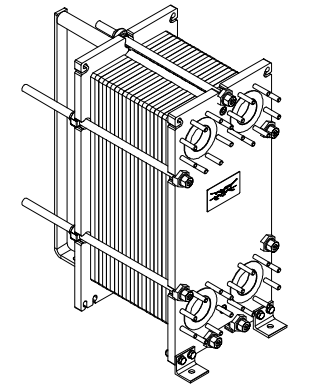

ASME B16.5 Class 150 NPS 4
S1, S2, S3, S4

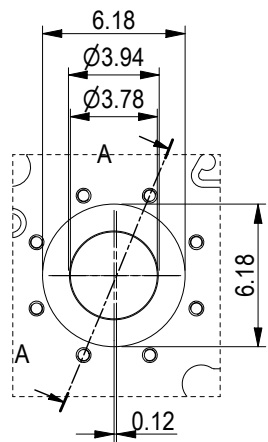

A-A:
ALLOY 316

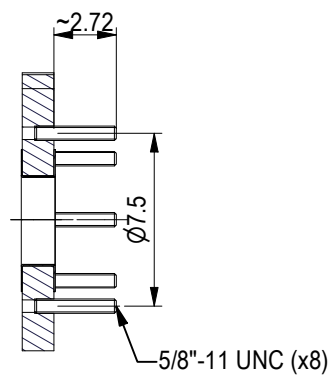

APPROX. OUTER DIMENSIONS	
LENGTH	34.3 in
WIDTH	18.9 in
HEIGHT	41.3 in
APPROX. WEIGHTS	
NET WEIGHT, EMPTY	798 lb
WEIGHT FULL OF WATER	950 lb
PLATE MATERIAL	ALLOY 316
PLATE THICKNESS	0.5 mm
GASKET	NBRP ClipGrip™

CHANNEL ARRANGEMENT 1*34 MH
/ 1*35 ML

NO. OF UNITS	1
CHANNEL	
MH	null GPM
ML	null GPM



www.alfalaval.com

DRAWING
GASKETED PLATE HEAT EXCHANGER
T10-MFG

ASME
Code Section VIII Div.1

MAWP 150 psi at 150.1 °F
MDMT 32.0 °F at 150 psi
Designed and constructed in accordance with the 2019 ASME Code.

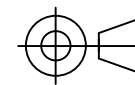

8240153008
T10-MFG, 70 plates

Do not use this drawing for foundation bolting or piping layout

DATE 5/2/22
REVISION 0